

---

# PXle-1086 Specifications

---

2024-05-06



# Contents

PXIe-1086 Specifications..... 3

# PXIe-1086 Specifications

This document contains specifications for the PXIe-1086 chassis.



**Caution** Specifications are subject to change without notice.

## Electrical

### AC Input

Input voltage range	100 to 240 VAC
Operating voltage range <sup>[1]</sup>	90 to 264 VAC
Input current rating	12 to 6 A
Input frequency	50/60 Hz
Operating frequency range <sup>1</sup>	47 to 63 Hz
Efficiency	70% typical
Power disconnect	The AC power cable provides main power disconnect. Do not position the equipment so that it is difficult to disconnect the power cord. The front-panel power switch causes the internal chassis power supply to provide DC power to the CompactPCI/PXI Express backplane. You also can use the front panel terminal block 4-pin connector and power mode switch to control the internal chassis power supply.

## DC Output

**Table 1.** DC current capacity ( $I_{mp}$ )

Voltage	Maximum Current Single Power Supply	Maximum Current Dual Power Supplies
+3.3 V	50 A	60 A
+5 V	40 A	49 A
+12 V	50 A	62 A
-12 V	4 A	4 A
5 V <sub>AUX</sub>	1.5 A	1.5 A



**Note** Maximum total usable power is 855 W. Maximum combined +12 V and -12 V power of a single power supply is 588 W .

**Table 2.** Backplane slot current capacity

Slot	+5 V	V (I/O)	+3.3 V	+12 V	-12 V	5 V <sub>AUX</sub>
System Controller Slot	15 A	-	15 A	30 A	-	1 A
System Timing Slot	-	-	6 A	4 A	-	1 A
Hybrid Peripheral Slot with PXI-1 Peripheral	6 A	5 A	6 A	1 A	1 A	-
Hybrid Peripheral Slot with PXI-5 Peripheral	-	-	6 A	4 A	-	1 A
PXI-1 Peripheral Slot	6 A	11 A	6 A	1 A	1 A	-



**Note** Total system slot current should not exceed 45 A.



**Note** PCI V(I/O) pins in PXI-1 peripheral slots and hybrid peripheral slots are connected to +5 V.



**Note** The maximum power dissipated in the system slot should not exceed 140 W.



**Note** The maximum power dissipated in a peripheral slot should not exceed 38.25 W.

**Table 3.** Load regulation

Voltage	Load Regulation
+3.3 V	<5%
+12 V	<5%
+5 V	<5%
-12 V	<5%

**Table 4.** Maximum ripple and noise (20 MHz bandwidth)

Voltage	Maximum Ripple and Noise
+3.3 V	50 mV <sub>pp</sub>
+12 V	120 mV <sub>pp</sub>
+5 V	50 mV <sub>pp</sub>
-12 V	120 mV <sub>pp</sub>
Over-current protection	All outputs protected from short circuit and overload with automatic recovery
Over-voltage protection, 3.3 V and 5 V	Clamped at 25 to 40% above nominal output voltage

Power supply shuttle MTTR	Replacement in under 1 minute
---------------------------	-------------------------------

## Chassis Cooling

Module cooling system	Forced air circulation (positive pressurization) through six 150 cfm fans (three sets of dual stacked fans) with High/Auto speed selector
Slot airflow direction	Bottom of module to top of module
Module cooling intake	Bottom of chassis
Module cooling exhaust	Along top of chassis
Power supply cooling system	Forced air circulation through integrated fan
Power supply cooling intake	Rear of chassis
Power supply cooling exhaust	Top of chassis
<b>Minimum chassis cooling clearances</b>	
Above	44.45 mm (1.75 in)
Rear	76.20 mm (3.00 in)
Sides	44.45 mm (1.75 in)

## Environmental

Maximum altitude	4,600 m (570 mbar) (at 25 °C ambient)
------------------	---------------------------------------



**Note** Fan speed selector must be set to High to meet the maximum altitude specification.

Pollution Degree	2
------------------	---

Indoor use only.

## Operating Environment

Ambient temperature range	0 °C to 50 °C (Tested in accordance with IEC-60068-2-1 and IEC-60068-2-2. Meets MIL-PRF-28800F Class 3 temperature limits.)
Relative humidity range	5% to 95%, noncondensing (Tested to temperature and humidity levels specified in MIL-PRF-28800F.)

## Storage Environment

Ambient temperature range	-40 °C to 71 °C (Tested in accordance with IEC-60068-2-1 and IEC-60068-2-2. Meets MIL-PRF-28800F Class 3 limits.)
Relative humidity range	5% to 95%, noncondensing (Tested in accordance with IEC-60068-2-56.)

## Shock and Vibration

Operational shock	30 g peak, half-sine, 11 ms pulse (Tested in accordance with IEC-60068-2-27. Meets MIL-PRF-28800F Class 2 limits.)
-------------------	--

Random Vibration Operating	5 to 500 Hz, 0.3 g <sub>rms</sub>
----------------------------	-----------------------------------



**Caution** When using a single power supply unit, you must use a power supply filler panel (NI P/N 784057-01) in the empty slot to meet operational shock and vibration specifications.

## Acoustic Emissions

### Sound Pressure Level (at Operator Position)

(Tested in accordance with ISO 7779. Meets MIL-PRF-28800F requirements.)

Auto fan (up to ~30 °C ambient)	57.0 dBA
High fan	69.0 dBA

### Sound Power

Auto fan (up to ~30 °C ambient)	63.3 dBA
High fan	79.3 dBA

## Safety Compliance Standards

This product is designed to meet the requirements of the following electrical equipment safety standards for measurement, control, and laboratory use:

- IEC 61010-1, EN 61010-1
- UL 61010-1, CSA C22.2 No. 61010-1





**Note** For safety certifications, refer to the product label or the [Product Certifications and Declarations](#) section.

## Electromagnetic Compatibility

This product meets the requirements of the following EMC standards for electrical equipment for measurement, control, and laboratory use:

- EN 61326-1 (IEC 61326-1): Class A emissions; Basic immunity
- EN 55011 (CISPR 11): Group 1, Class A emissions
- AS/NZS CISPR 11: Group 1, Class A emissions
- FCC 47 CFR Part 15B: Class A emissions
- ICES-001: Class A emissions



**Note** In the United States (per FCC 47 CFR), Class A equipment is intended for use in commercial, light industrial, and heavy industrial locations. In Europe, Canada, Australia, and New Zealand (per CISPR 11), Class A equipment is intended for use only in heavy industrial locations.



**Note** Group 1 equipment (per CISPR 11) is any industrial, scientific, or medical equipment that does not intentionally generate radio frequency energy for the treatment of material or inspection/analysis purposes.



**Note** For EMC declarations and certifications and additional information, refer to the **Online Product Certification** section

## CE Compliance

This product meets the essential requirements of applicable European Directives, as follows:

- 2014/35/EU; Low-Voltage Directive (safety)

- 2014/30/EU; Electromagnetic Compatibility Directive (EMC)
- 2011/65/EU; Restriction of Hazardous Substances (RoHS)
- 2014/53/EU; Radio Equipment Directive (RED)
- 2014/34/EU; Potentially Explosive Atmospheres (ATEX)

## Product Certifications and Declarations

Refer to the product Declaration of Conformity (DoC) for additional regulatory compliance information. To obtain product certifications and the DoC for NI products, visit [ni.com/product-certifications](http://ni.com/product-certifications), search by model number, and click the appropriate link.

## Environmental Management

NI is committed to designing and manufacturing products in an environmentally responsible manner. NI recognizes that eliminating certain hazardous substances from our products is beneficial to the environment and to NI customers.

For additional environmental information, refer to the **Engineering a Healthy Planet** web page at [ni.com/environment](http://ni.com/environment). This page contains the environmental regulations and directives with which NI complies, as well as other environmental information not included in this document.

## 电子信息产品污染控制管理办法（中国 RoHS）

-  中国 RoHS— NI 符合中国电子信息产品中限制使用某些有害物质指令(RoHS)。关于 NI 中国 RoHS 合规性信息，请登录 [ni.com/environment/rohs\\_china](http://ni.com/environment/rohs_china)。(For information about China RoHS compliance, go to [ni.com/environment/rohs\\_china](http://ni.com/environment/rohs_china).)

## EU and UK Customers

-  Waste Electrical and Electronic Equipment (WEEE)—At the end of the product life cycle, all NI products must be disposed of according to local laws

and regulations. For more information about how to recycle NI products in your region, visit [ni.com/environment/weee](http://ni.com/environment/weee).

## Backplane

Size	3U-sized; one system slot (with three system expansion slots) and 17 peripheral slots. Compliant with IEEE 1101.10 mechanical packaging. PXI Express Specification compliant. Accepts both PXI Express and CompactPCI (PICMG 2.0 R 3.0) 3U modules.
Backplane bare-board material	UL 94 V-0 Recognized
Backplane connectors	Conforms to IEC 917 and IEC 1076-4-101, UL 94 V-0 rated

## 10 MHz System Reference Clock: PXI\_CLK10

Maximum slot-to-slot skew	1 ns
Accuracy	±25 ppm max (guaranteed over the operating temperature range)
Maximum jitter	5 ps RMS phase-jitter (10 Hz–1 MHz range)
Duty-factor	45% to 55%
Unloaded signal swing	3.3 V ±0.3 V



**Note** For other specifications, refer to the **PXI-1 Hardware Specification**.

## 100 MHz System Reference Clock: PXIe\_CLK100 and PXIe\_SYNC100

Maximum slot-to-slot skew	100 ps
Accuracy	±25 ppm max (guaranteed over the operating temperature range)
Maximum jitter	3 ps RMS phase-jitter (10 Hz to 12 kHz range), 2 ps RMS phase-jitter (12 kHz to 20 MHz range)
Duty-factor for PXIe_CLK100	45% to 55%
Absolute differential voltage (When terminated with a 50 Ω load to 1.30 V or Thévenin equivalent)	400 to 1000 mV



**Note** For other specifications, refer to the **PXI-5 PXI Express Hardware Specification**

## External 10 MHz Reference Out

(BNC on rear panel of chassis)

Accuracy	±25 ppm max (guaranteed over the operating temperature range)
Maximum jitter	5 ps RMS phase-jitter (10 Hz to 1 MHz range)
Output amplitude	1 V <sub>PP</sub> ±20% square-wave into 50 Ω, 2 V <sub>PP</sub> unloaded
Output impedance	50 Ω ±5 Ω

## External Clock Source

Frequency	10 MHz $\pm$ 100 ppm
<b>Input amplitude</b>	
Rear panel BNC	200 mV <sub>PP</sub> to 5 V <sub>PP</sub> square-wave or sine-wave
System timing slot PXI_CLK10_IN	5 V or 3.3 V TTL signal
Front-panel SMA input impedance	50 $\Omega$ $\pm$ 5 $\Omega$
Maximum jitter introduced by backplane	1 ps RMS phase-jitter (10 Hz to 1 MHz range)

## PXIe\_SYNC\_CTRL

V <sub>IH</sub>	2.0 to 5.5 V
V <sub>IL</sub>	0 to 0.8 V

## PXI Star Trigger

Maximum slot-to-slot skew	250 ps
Backplane characteristic impedance	65 $\Omega$ $\pm$ 10%

For other specifications, refer to the **PXI-1 Hardware Specification**.

## PXI Differential Star Triggers

(PXIe-DSTARA, PXIe-DSTARB, PXIe-DSTARC)

Maximum slot-to-slot skew	150 ps
Maximum differential skew	25 ps
Backplane differential impedance	100 $\Omega$ $\pm$ 10%

For other specifications, the PXIe-1086 complies with the **PXI-5 PXI Express Hardware Specification**.

## Mechanical

<b>Standard chassis dimensions</b>	
Height	10.59 in. (268.7 mm)
Width	18.39 in. (467.1 mm)
Depth	18.76 in. (476.5 mm)

<b>Weight</b>	
With two power supplies	37.6 lb. (17.1 kg)
With single power supply	31.5 lb. (14.3 kg)
Chassis materials	Sheet Aluminum (5052-H32, 3003-H14, and 6061-T6), Extruded Aluminum (6060-T6), and Cold Rolled Steel, PC-ABS, Santoprene, Nylon
Finish	Conductive Clear Iridite on Aluminum, Electroplated Nickel on Cold Rolled Steel, Polyurethane Enamel

The following figures show the PXIe-1086 chassis dimensions. The holes shown are for the installation of the optional rack mount kits. You can install those kits on the front or rear of the chassis, depending on which end of the chassis you want to face toward the front of the instrument cabinet. Notice that the front and rear chassis mounting holes (size M4) are symmetrical.

**Figure 1. PXIe-1086 Chassis Dimensions (Front and Side)**

Dimensions are in inches (millimeters)

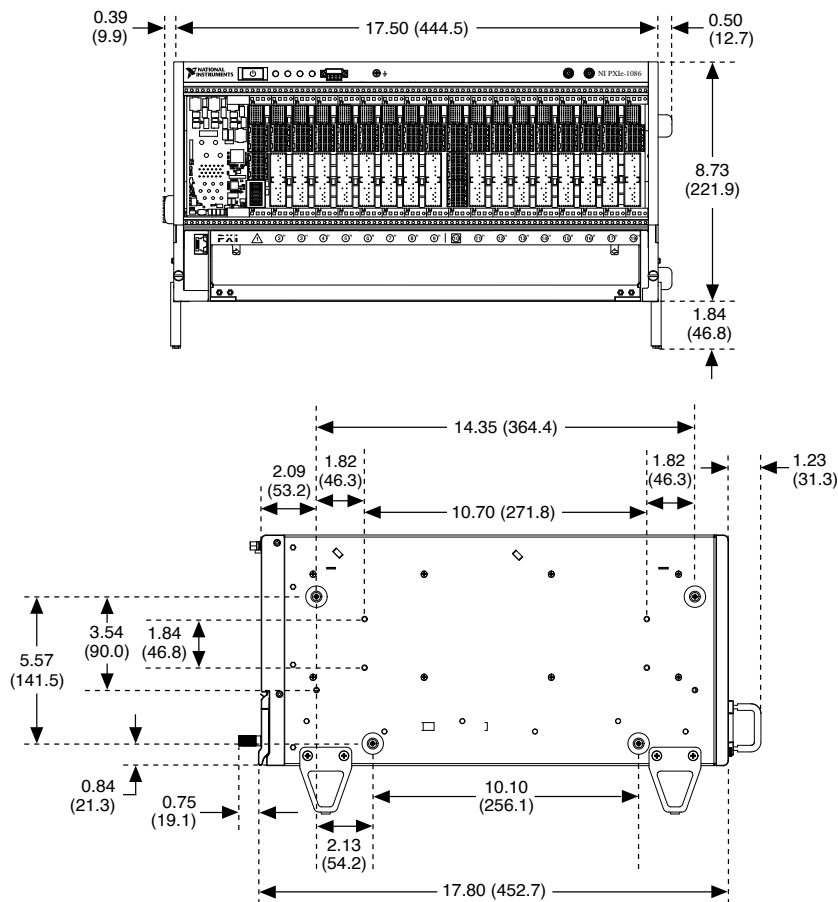

**Figure 1. PXIe-1086 Chassis Dimensions (Bottom)**

Dimensions are in inches (millimeters)

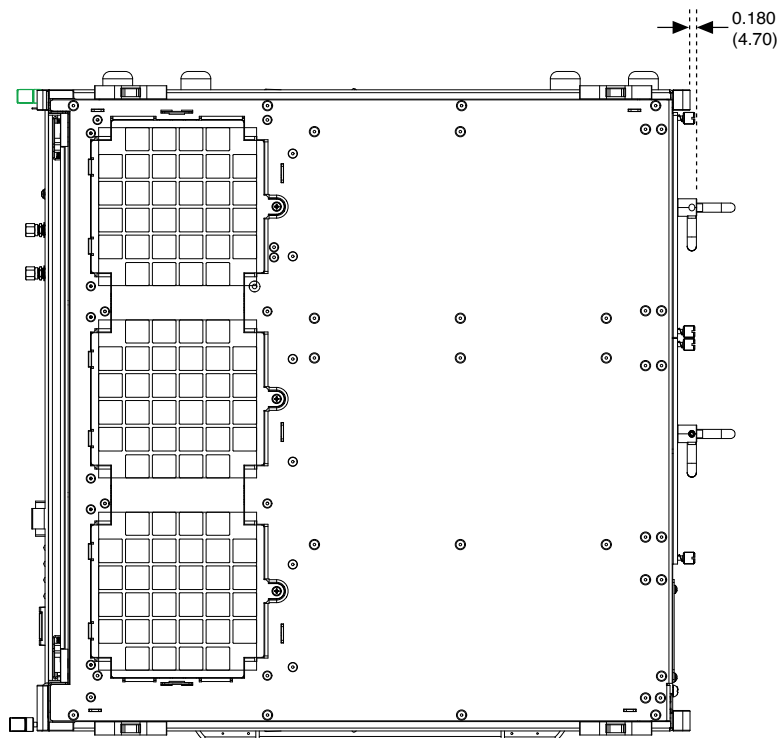
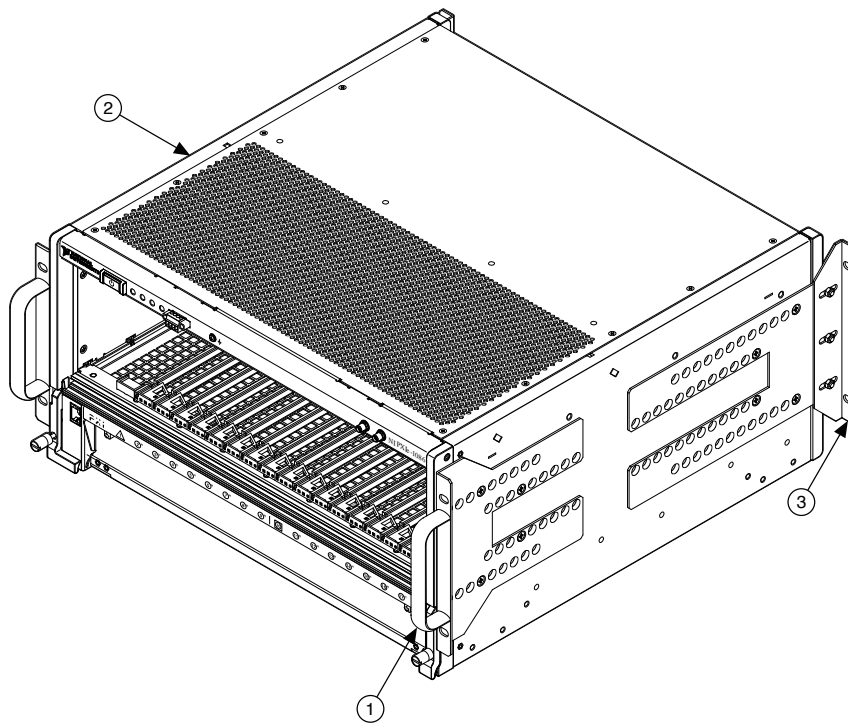
**Figure 3. NI Chassis Rack Mount Kit Components**



1. Front Rack Mount Kit
2. PXIe-1086 Chassis
3. Rear Rack Mount Kit